

TFP DOUBLE VANE PUMPS V2010/V2020

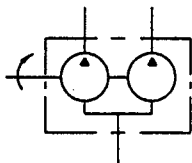

- * High Performance
- * Low Cost
- * Extended Life
- * Versatile
- * Compact
- * Quiet Operation
- * Hydraulic Balance

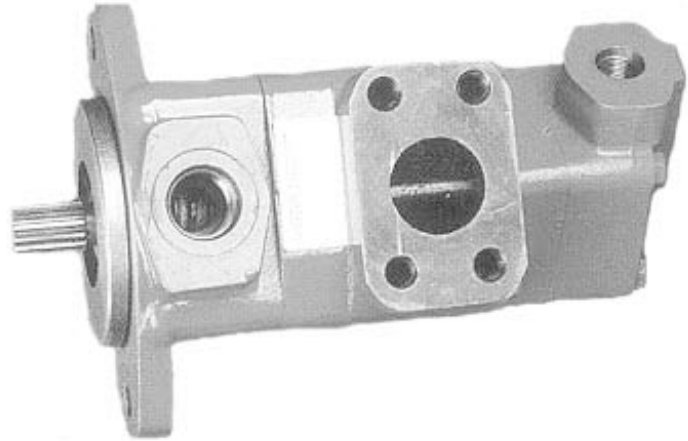

◆ Double Pump Ordering Specifications

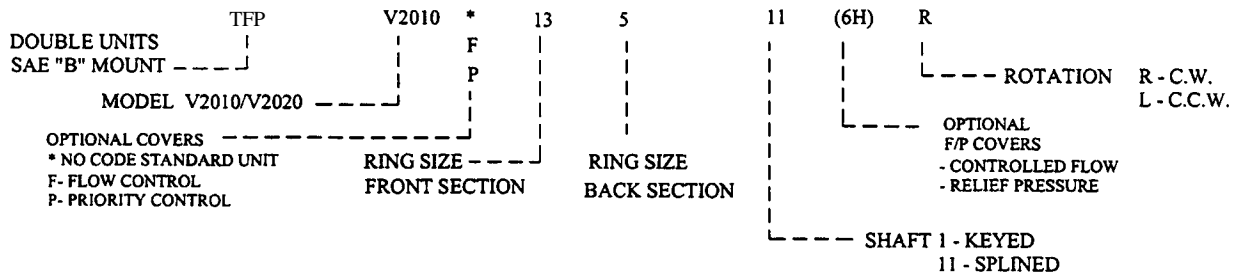

Values based on using anti-wear type petroleum oil 150 SUS at 100°F and 0 PSI inlet pressure.

Model Series	FRONT SECTION						BACK SECTION						Weight lbs.
	Delivery USgpm @ 1200 rpm 100 psi	Displ. cu.in./ rev.	Max. rpm.	Max. psi.	Typical delivery USgpm @ max.speed & pressure	Typical input HP @ max.speed & pressure	Delivery USgpm @ 1200 rpm 100 psi	Displ. cu.in./ rev.	Max. rpm	Max. psi	Typical delivery USgpm @ max.speed & pressure	Typical input HP @ max.speed & pressure	
V2010	6	1.19	3000	2500	14.5	24.5	1	.20	3000	2500	2	4.5	30
	7	1.39	3000	2500	16.5	30	2	.40	3000	2500	4.7	9	
	8	1.62	2800	2500	17.5	32.5	3	.60	3000	2500	7	13.4	
	9	1.81	2800	2500	20	36	4	.80	3000	2500	9.5	18	
	11	2.22	2500	2500	23	37.5	5	1.00	3000	2500	12	21.5	
	12	2.38	2400	2500	23	36	6	1.19	3000	2500	14.5	24.5	
V2020	13	2.59	2400	2500	26	39	7	1.39	2800	2500	16	24	35
	6	1.19	3000	2500	14.5	24.5	6	1.19	3000	2500	14.5	24.5	
	7	1.39	3000	2500	16.5	30	7	1.39	3000	2500	16.5	30	
	8	1.62	2800	2500	17.5	32.5	8	1.62	2800	2500	17.5	32.5	
	9	1.81	2800	2500	20	36	9	1.81	2800	2500	20	36	
	11	2.22	2500	2500	23	37.5	11	2.22	2500	2500	23	37.5	
	12	2.38	2400	2500	23	36							
13	2.59	2400	2500	26	39								

TFP offers a complete line of economical, high performance fixed displacement double vane pumps that provide flows up to 26/23 US GPM per section for Mobile and Industrial applications. Balanced vane design provides quiet operation, high efficiency and long service life for the toughest applications. Units are designed for use with oil or synthetic fire resistant fluid. A large combination of factory tested cartridges are available for fast and easy conversion and repairs.

TFP V2010 DOUBLE VANE PUMP INSTALLATION DIMENSIONS



DIMENSIONS (inches)

V2010 Series
Optional Shaft

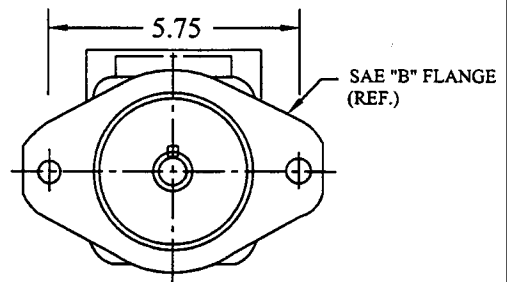
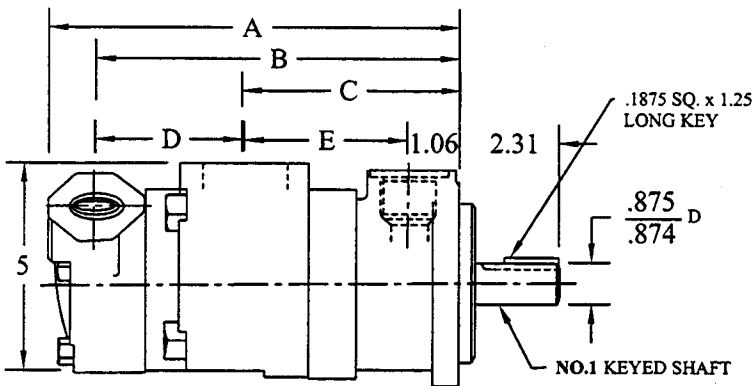
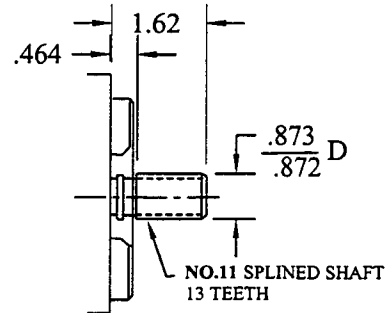
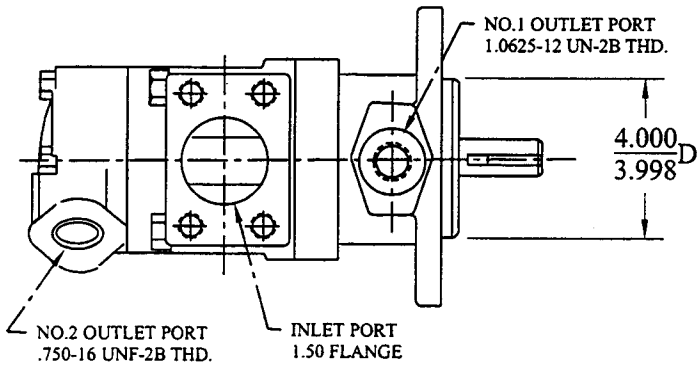

DIMENSIONS

RATED DELIVERY GPM @ 1200 RPM & 100 PSI		DIMENSIONS				
Shaft End	Cover End	A	B	C	D	E
7, 8 or 9	1,2 or 3	8.39	7.45	4.46	2.99	3.40
7, 8 or 9	4 or 5	8.64	7.70	4.46	3.24	3.40
7, 8 or 9	6 or 7	8.84	7.90	4.46	3.44	3.40
11	1,2 or 3	8.59	7.65	4.65	2.99	3.59
11	4 or 5	8.84	7.90	4.65	3.24	3.59
11	6 or 7	9.04	8.10	4.65	3.44	3.59
12 or 13	1,2 or 3	8.73	7.79	4.79	2.99	3.73
12 or 13	4 or 5	8.97	8.03	4.79	3.24	3.73
12 or 13	6 or 7	8.23	8.03	4.79	3.44	3.73

Weight 30 lbs.

TFP V2020 DOUBLE VANE PUMP INSTALLATION DIMENSIONS



DIMENSIONS (inches)

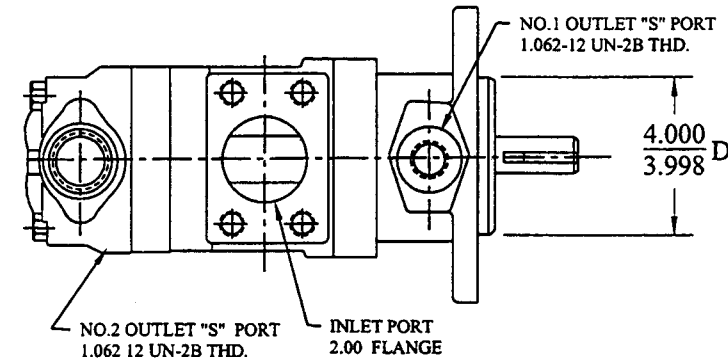

V2020 Series
Optional Shaft

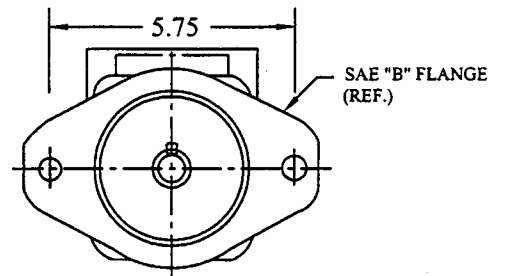
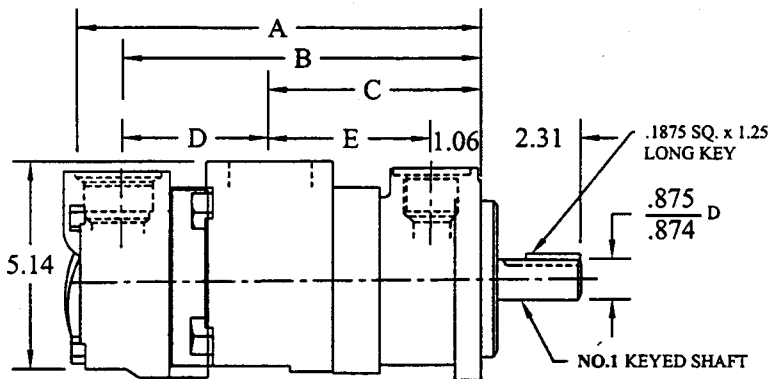
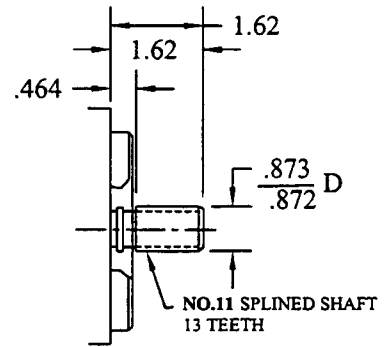

DIMENSIONS

RATED DELIVERY GPM @ 1200 RPM & 100 PSI		DIMENSIONS				
Shaft End	Cover End	A	B	C	D	E
7, 8 or 9	6	8.41	7.39	4.49	2.90	3.43
7, 8 or 9	7, 8 or 9	8.66	7.64	4.49	3.15	3.43
11	6	8.61	7.59	4.69	2.90	3.63
11	7, 8 or 9	8.86	7.84	4.69	3.15	3.63
11	11	9.05	8.03	4.69	3.35	3.63
12 or 13	6	8.75	7.73	4.82	2.90	3.76
12 or 13	7, 8 or 9	8.99	7.97	4.82	3.15	3.76
12 or 13	11	9.19	8.17	4.82	3.35	3.76
Weight 35 lbs.						

TFP V2010 VANE PUMP SERVICE PARTS INFORMATION

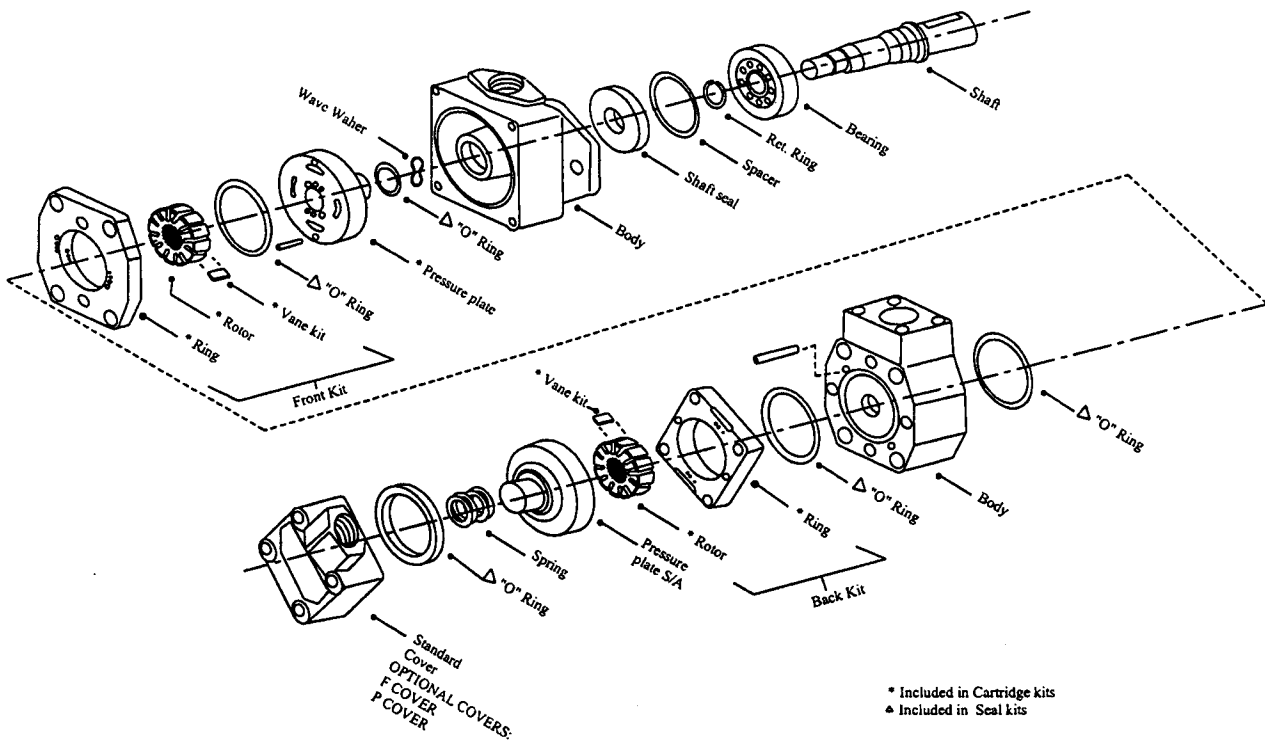

PUMP SE	FRONT C. KIT	FRONT ROTOR	FRONT VANE	FRONT RING	FRONT PR. PL.	BACK C. KIT	BACK ROTOR	BACK VANE	BACK RING	BACK PR. PL.
V2010	6 923474N	358339N	923493N	328152N	358347N	1 923471N	317681N	923499N	317674N	373795N
	7 923494N			328152N		2 923470N			317675N	
	8 923495N			331791N		3 923496N			317676N	
	9 923462N	331789N	4 923469N	351247N		923500N	317677N			
	11 923475N	358336N	923478N	328156N		5 923468N	317678N			
	12 923476N	358337N	923479N	331806N		6 923497N	357286N	923501N	355641N	
	13 923477N			331807N		7 923498N			331813N	

PUMP SE	SEAL KIT	SEAL	BEARING	BODY	SHAFT NO.
V2010	923577N	229236N	82938N	357292N	SHAFT 1. NO. 351249N
					SHAFT 11. NO. 321215N

- All Cartridge assemblies are factory tested before shipping -

Bolt Torques

	FRONT SECTION	BACK SECTION
V2010	85 LBS/FT.	45 LBS/FT.

Changing Cartridge Rotation

Reposition the ring 90 degrees from its original position using the locating pins for alignment, and making sure the arrow on the perimeter points in the proper direction of rotation. Install the rotor on shaft and insert vanes in the rotor slots. Be certain the radius edges of the vanes are towards the cam ring.

TFP V2020 VANE PUMP SERVICE PARTS INFORMATION

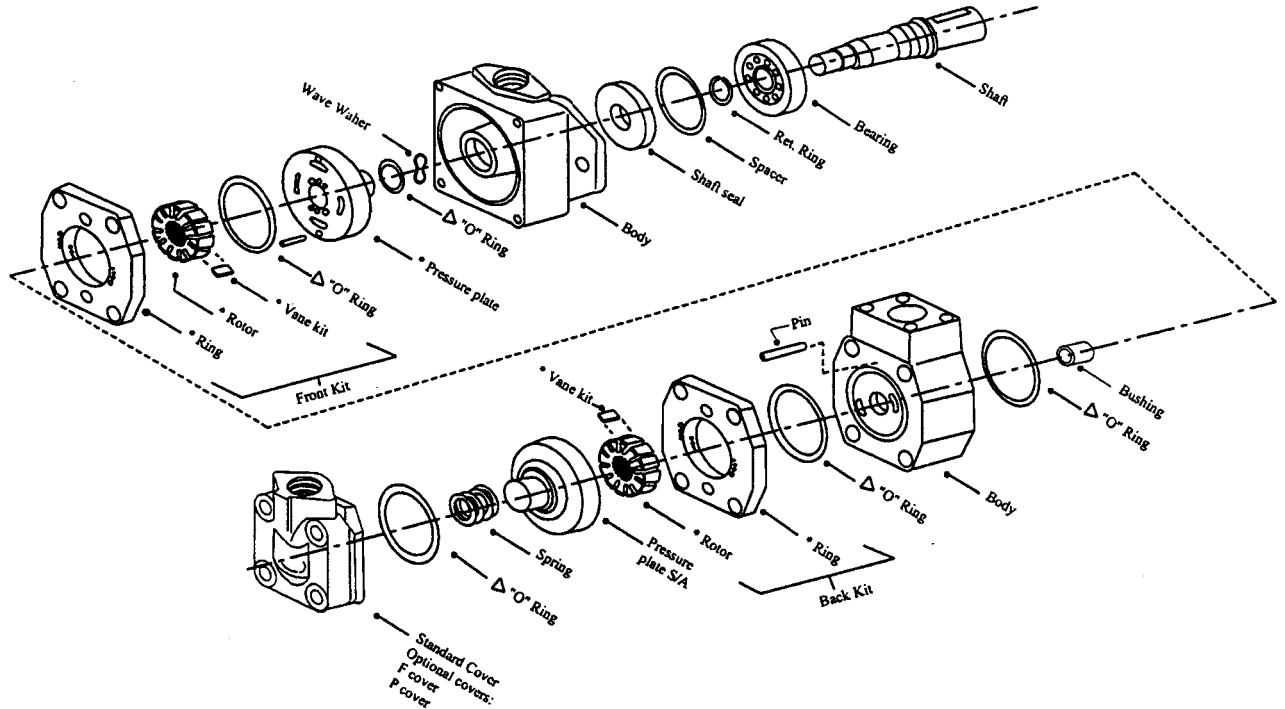

▲ INCLUDED IN SEAL KIT
* INCLUDED IN CARTRIDGE KIT

PUMP SE	FRONT C. KIT	FRONT ROTOR	FRONT VANES	FRONT RING	FRONT PR. PL.	BACK C. KIT	BACK ROTOR	BACK VANES	BACK RING	BACK PR. PL.
V2020	6 923474N	358339N	923493N	328152N	358347N	6 923480N	358328N	923485N	328150N	358347N
	7 923494N	358335N	923493N	328152N		7 923481N	358330N	923493N	328152N	
	8 923495N			331791N		8 923483N			331791N	
	9 923462N			331789N		9 923484N			331789N	
	11 923475N	358336N	923478N	328156N		11 923482N	358332N	923478N	328156N	
	12 923476N	358337N	923479N	331806N						
	13 923477N			331807N						

PUMP SE	SEAL KIT	SEAL	BEARING	BODY	SHAFT NO.
V2020	923174N	229236N	82938N	308681N	SHAFT I. NO. 308686N SHAFT II. NO. 308926N

- All Cartridge assemblies are factory tested before shipping -

Bolt Torques

	FRONT SECTION	BACK SECTION
V2020		81 LBS/FT.

Changing Cartridge Rotation

Reposition the ring 90 degrees from its original position using the locating pins for alignment, and making sure the arrow on the perimeter points in the proper direction of rotation. Install the rotor on shaft and insert vanes in the rotor slots. Be certain the radius edges of the vanes are towards the cam ring.

TFP V2010/V2020 DOUBLE VANE PUMP OPTIONAL PORT POSITIONS

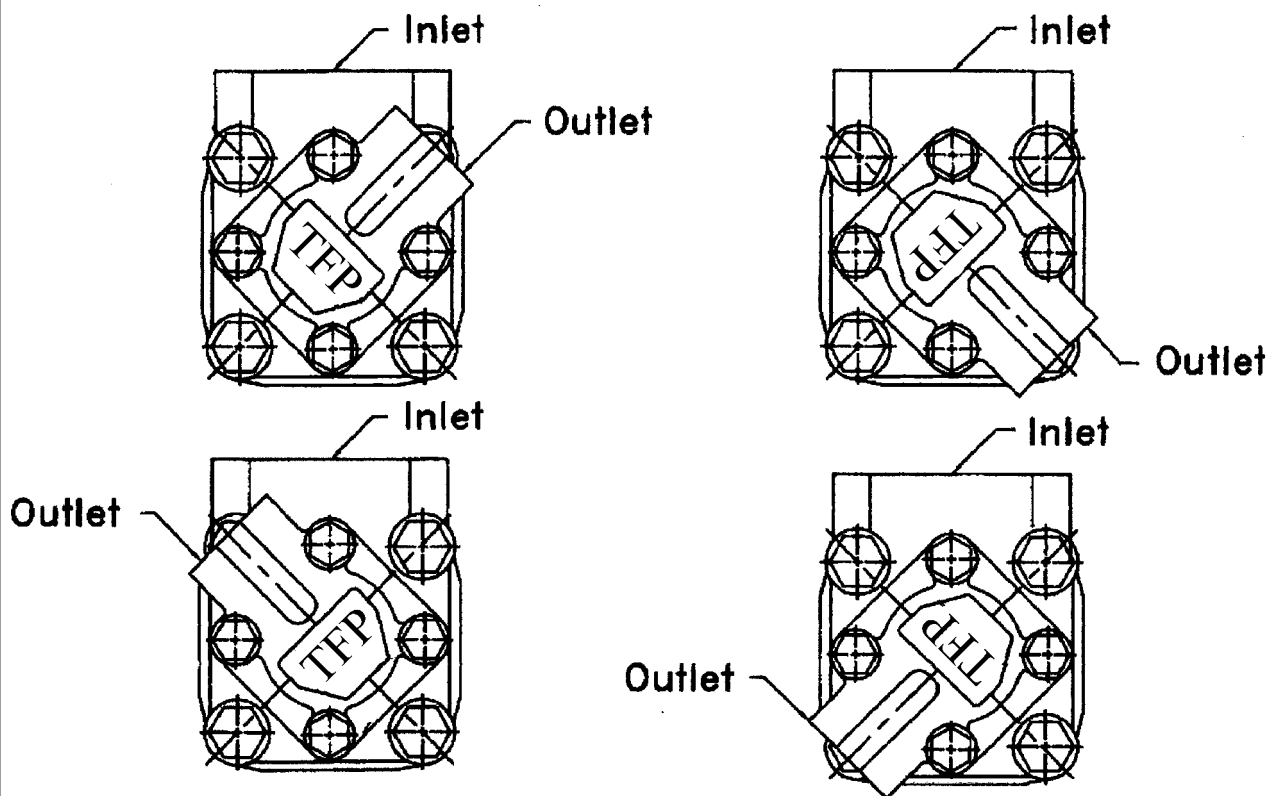

Note: Remove rear cover bolts, Rotate cover for proper port position
Torque bolts to 45 ft/lbs

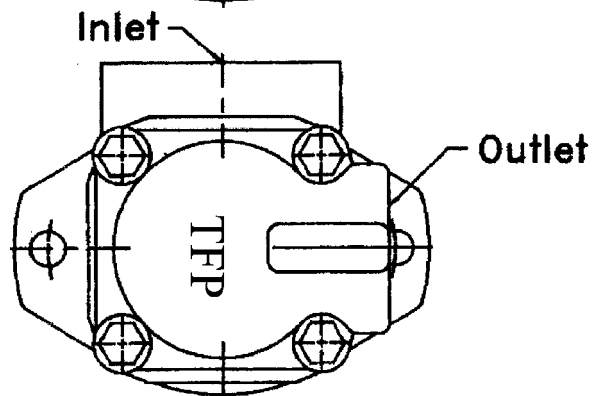
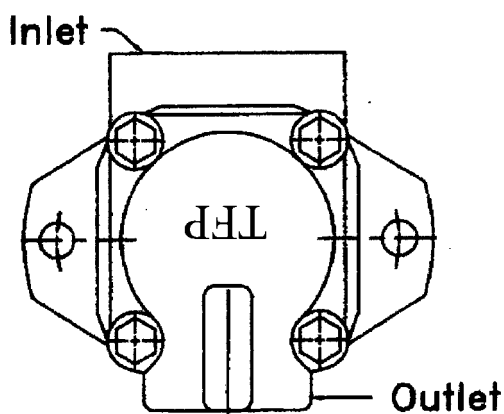
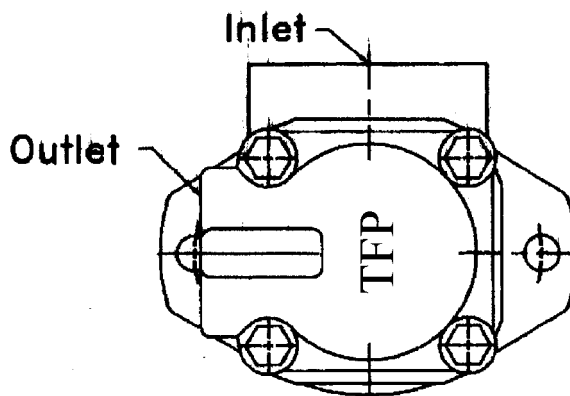
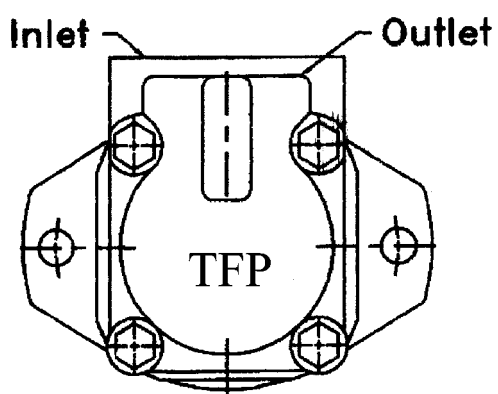

Torque bolts to 80 ft/lbs