

# TFP 25VQT VANE PUMP

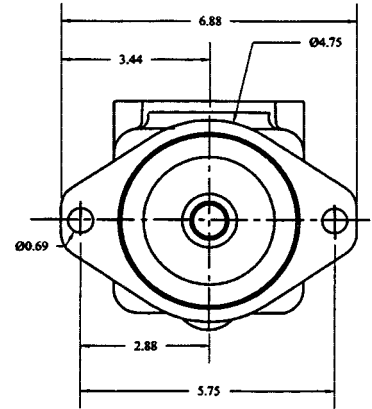
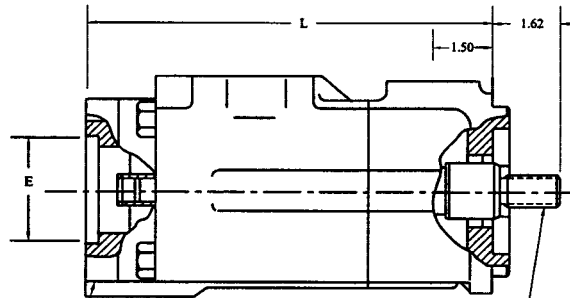
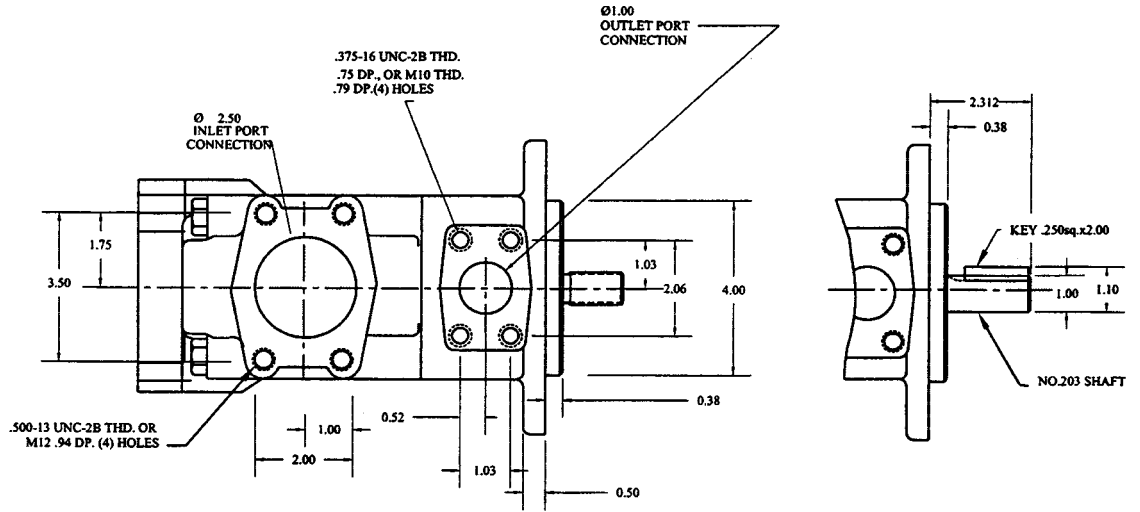

NOTE-A/B ADAPTERS AVAILABLE, SEE PAGE A5.4

NO.297 SHAFT INVOLUTE SPLINE. FLAT ROOT, SIDE FIT 13 TEETH, 16/32 PITCH. 30° PRESSURE ANGLE .875/.853 MAJOR DIA. .725 MINOR DIAMETER.

## ◆ 25VT/VQT Pump Ordering Specifications

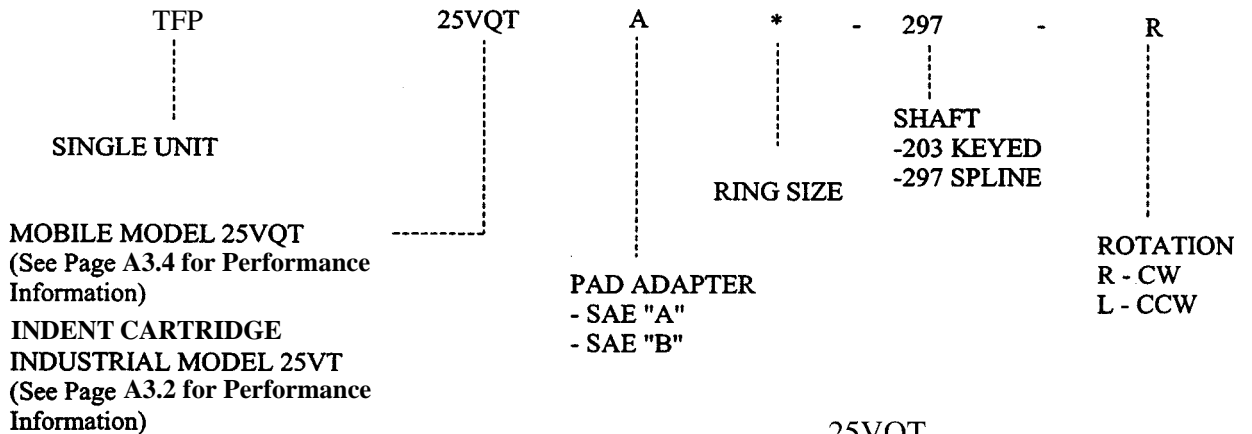

25VQT

Adaptor	"L"	"E"
SAE A	9.3"	3.253" Dia
SAE B	9.7"	4.003" Dia

# TFP 35VQT VANE PUMP

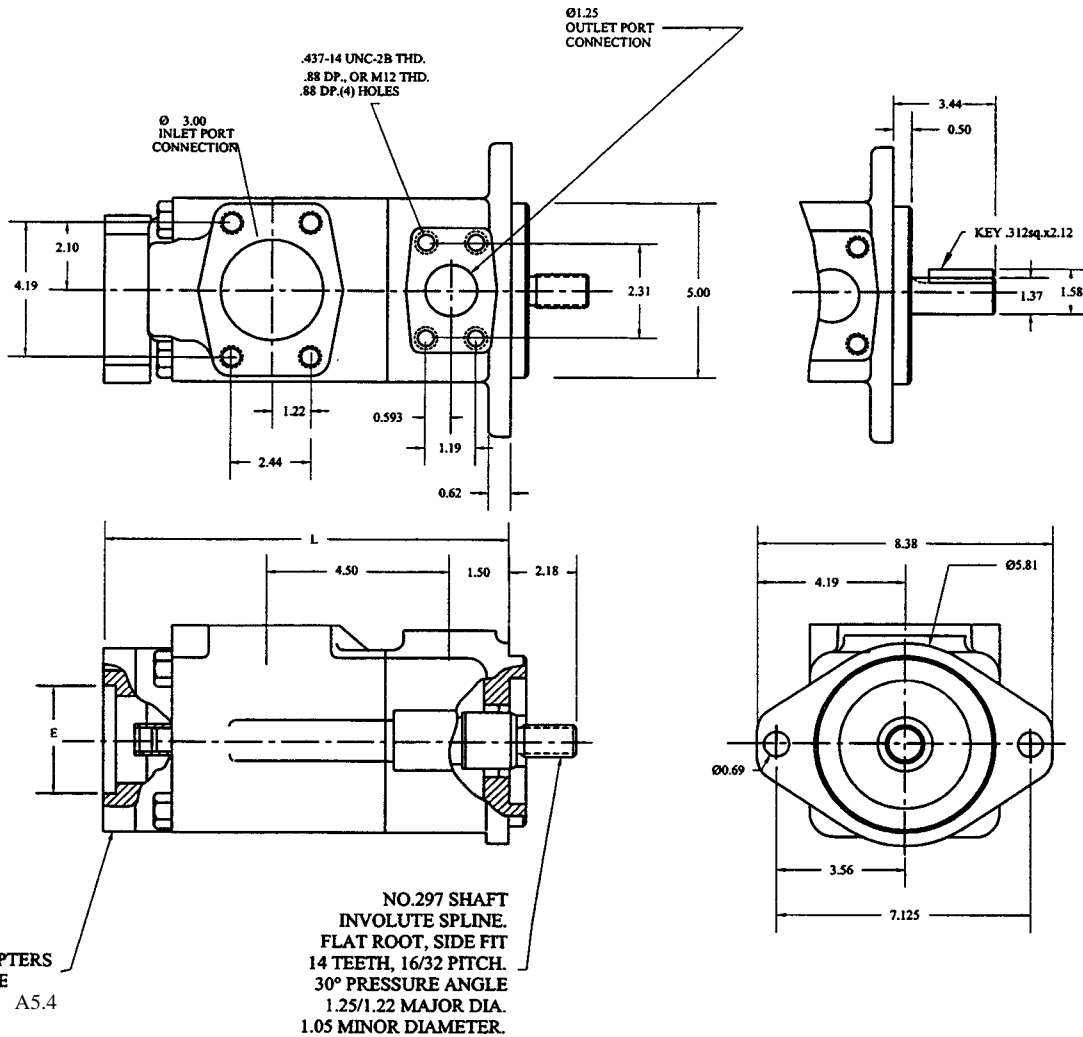

NOTE-A/B/C ADAPTERS AVAILABLE, SEE PAGE A5.4

## ◆ 35VT/VQT Pump Ordering Specifications

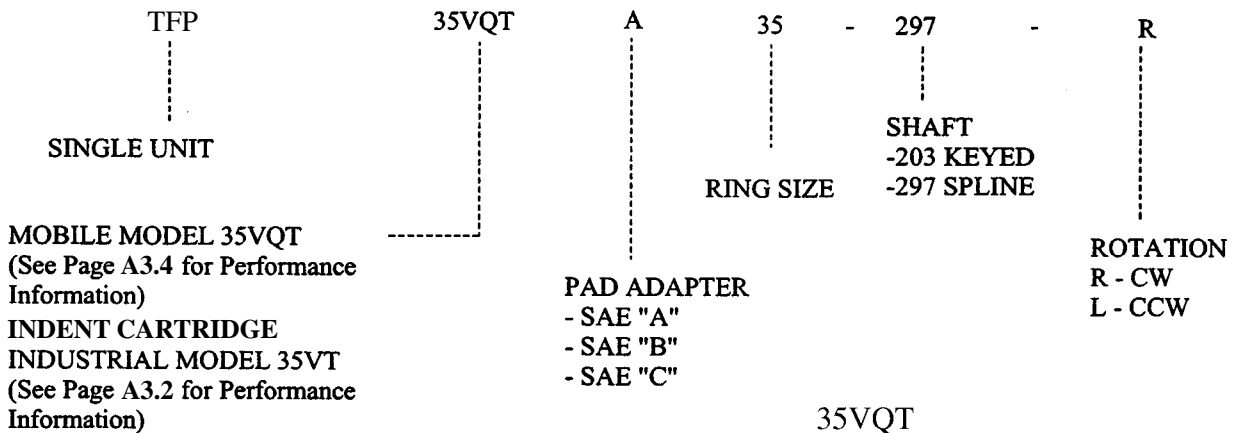

35VQT

Adaptor	"L"	"E"
SAE A	10.2"	3.253" Dia
SAE B	10.6"	4.003" Dia
SAE C	10.9"	5.003" Dia

# TFP 45VQT VANE PUMP

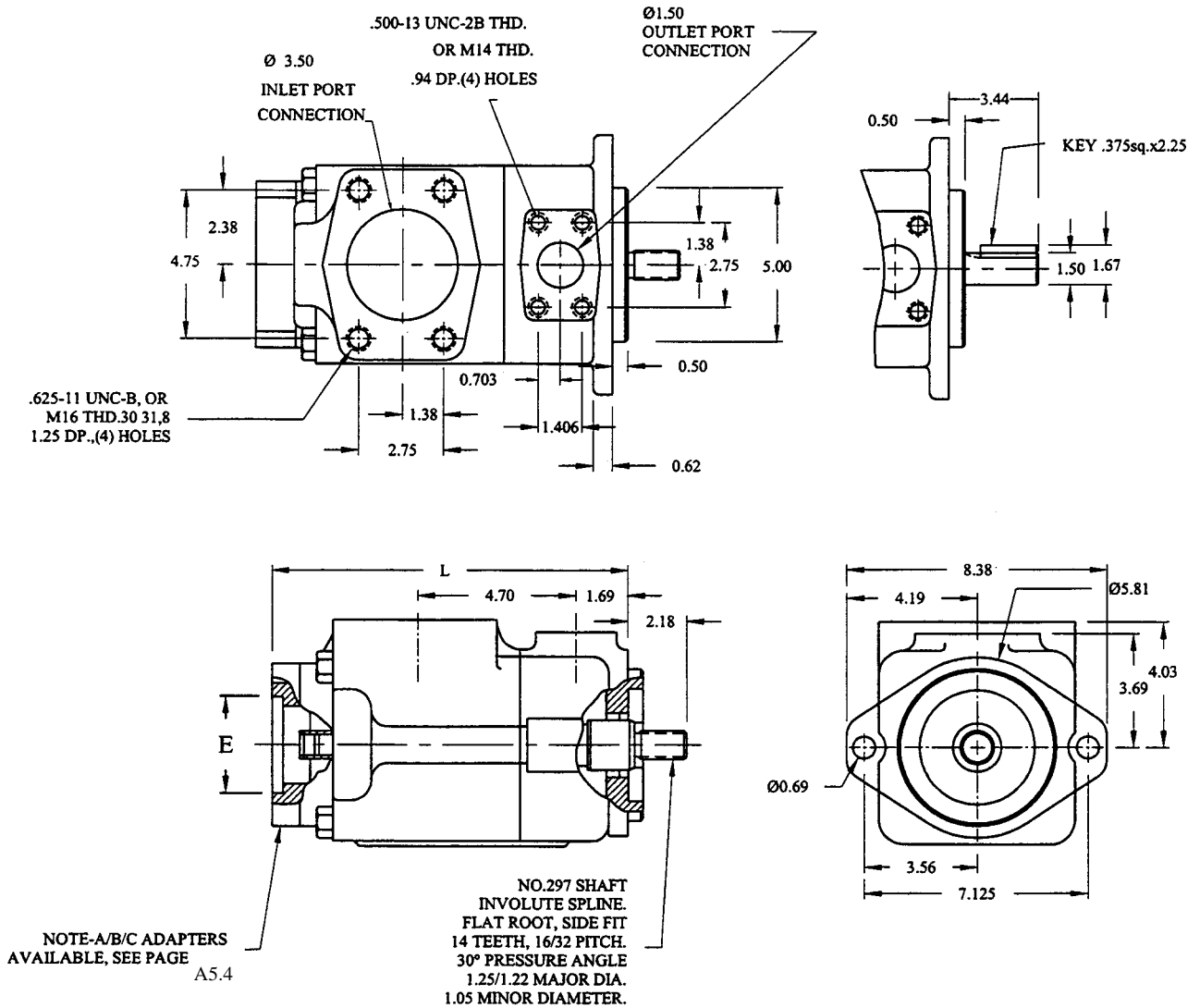

## ◆ 45VT/VQT Pump Ordering Specifications

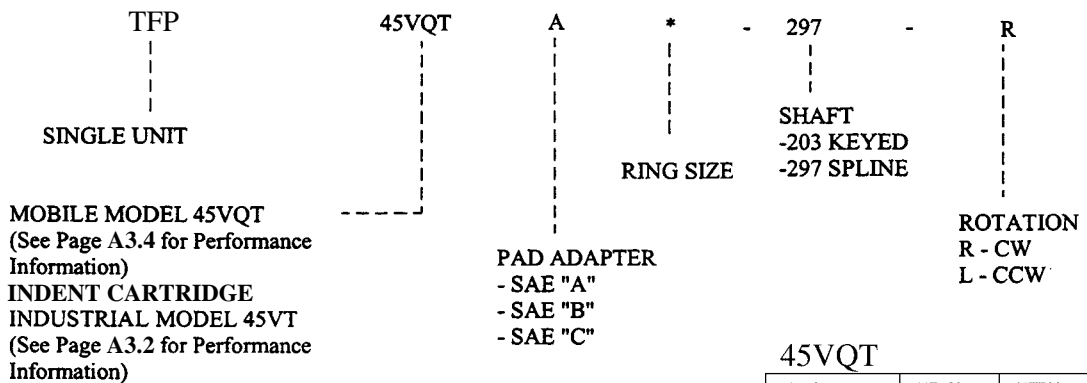

45VQT

Adaptor	"L"	"E"
SAE A	11.5"	3.253" Dia
SAE B	11.8"	4.003" Dia
SAE C	12.1"	5.003" Dia

# TFP "VT" PUMP ADAPTERS



## "A" REAR MOUNT

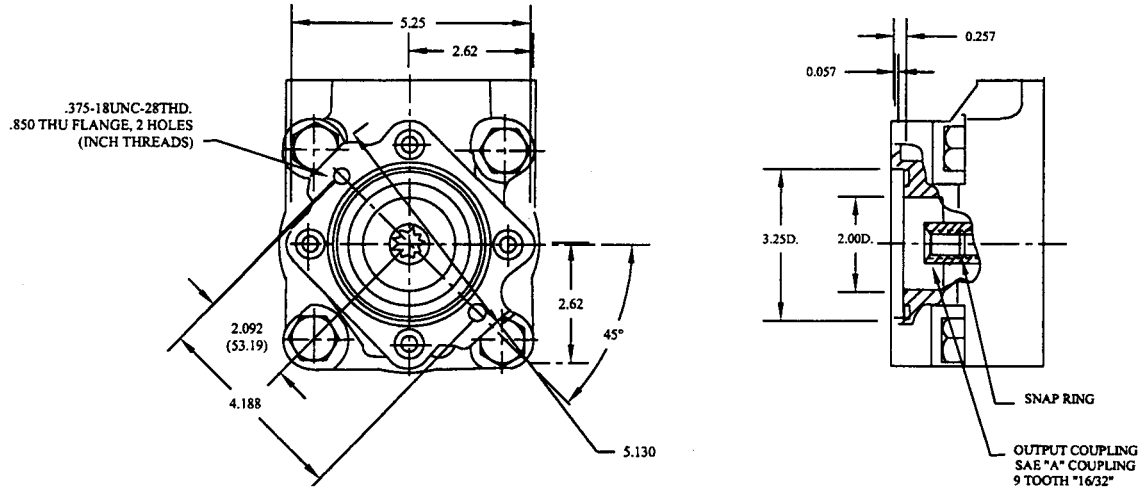

## "B" REAR MOUNT

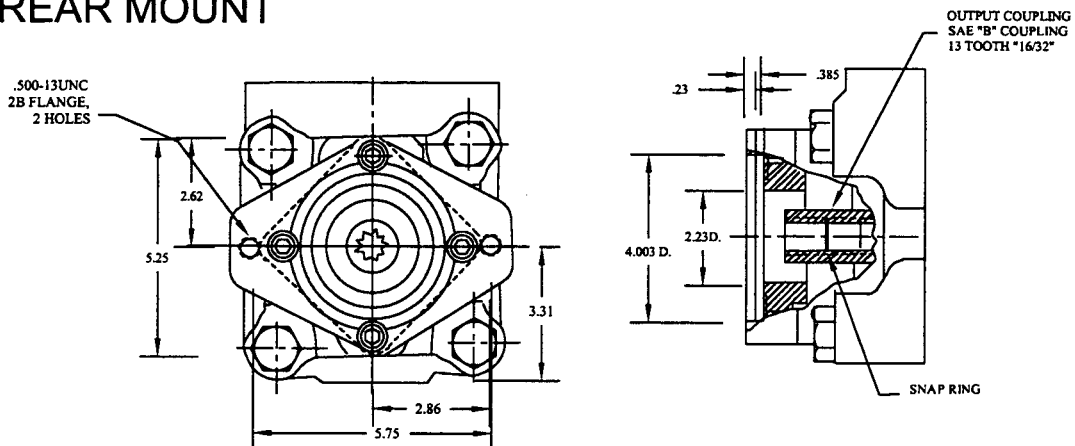

## "C" REAR MOUNT

